

Highload Anchor SZ

Steel, zinc plated

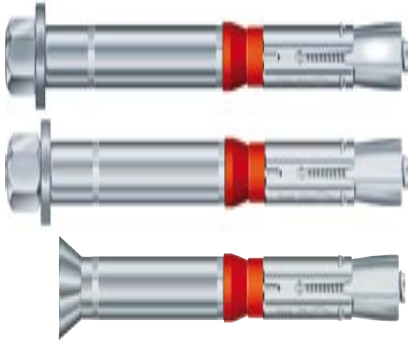

Highload Anchor SZ-S

Highload Anchor SZ-B

Highload Anchor SZ-SK



Description

The Highload Anchor SZ is a torque controlled expansion anchor system (ETA, Option 1), designed for fast through fastening in cracked and non-cracked concrete, available in three versions. It may be used for anchorages with fire resistance requirements. The SZ is shock approved.

Applications

Medium to heavy duty anchoring of base plates, supports, pallet racks, brackets, railings in cracked and non-cracked concrete

Range of loading: 2,4 kN - 73,8 kN
Range of concrete quality: C20/25 - C50/60

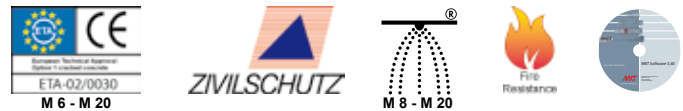

Highload Anchor SZ



- Steel, zinc plated
- ETA approval for cracked and non-cracked concrete

Highload Anchor SZ-SK



- Steel, zinc plated; with countersunk head
- ETA approval for cracked and non-cracked concrete

Description	Type SZ-S	Type SZ-B	Drill hole Øxdepth	Setting- depth	Anchor- length		Fixture thick- ness t _{fix}	Thread	Pkg. cont.	Weight per pkg.
	Ref. No.	Ref. No.			Typ S mm	Typ B mm				
SZ 10-0	14005301	16005301	10x65	60	65	67	0	M 6	100	3,30
SZ 10-10	14010301	16010301	10x65	60	75	77	10	M 6	50	2,00
SZ 10-30	14025301	16025301	10x65	60	95	97	30	M 6	50	2,40
SZ 10-50	14030301	16030301	10x65	60	115	117	50	M 6	50	3,30
SZ 10-100	-	16045301	10x65	60	-	167	100	M 6	25	2,25
SZ 12-0	14105301	16105301	12x80	70	75	80	0	M 8	50	3,00
SZ 12-10	14110301	16110301	12x80	70	85	90	10	M 8	50	3,30
SZ 12-30	14125301	16125301	12x80	70	105	110	30	M 8	50	4,00
SZ 12-50	14130301	16130301	12x80	70	125	130	50	M 8	25	2,50
SZ 12-100	-	16145301	12x80	70	-	180	100	M 8	25	3,45
SZ 15-0	14205301	16205301	15x95	85	91	96	0	M 10	25	2,80
SZ 15-15	14215301	16215301	15x95	85	106	111	15	M 10	25	3,20
SZ 15-25	14220301	16220301	15x95	85	116	121	25	M 10	25	3,50
SZ 15-45	14225301	16225301	15x95	85	136	141	45	M 10	25	4,00
SZ 15-95	14240301	16240301	15x95	85	186	191	95	M 10	25	5,40
SZ 18-0	14305301	16305301	18x105	95	107	112	0	M 12	20	3,80
SZ 18-10	14310301	16310301	18x105	95	117	122	10	M 12	20	4,10
SZ 18-20	14315301	16315301	18x105	95	127	132	20	M 12	20	4,40
SZ 18-40	14325301	16325301	18x105	95	147	152	40	M 12	20	5,10
SZ 18-70	14335301	16335301	18x105	95	177	182	70	M 12	20	6,10
SZ 18-100	-	16340301	18x105	95	-	212	100	M 12	10	3,55
SZ 24-0	14505301	16505301	24x130	120	130	137	0	M 16	10	4,10
SZ 24-20	14515301	16515301	24x130	120	150	157	20	M 16	10	4,70
SZ 24-50	14525301	16525301	24x130	120	180	187	50	M 16	10	5,50
SZ 24-100	-	16530301	24x130	120	-	237	100	M 16	5	3,50
SZ 24-0 L	14555301	16555301	24x145	135	150	152	0	M 16	10	4,70
SZ 24-30 L	14565301	16565301	24x145	135	180	182	30	M 16	10	5,50
SZ 24-50 L	14575301	16575301	24x145	135	200	202	50	M 16	10	6,20
SZ 28-10	14610301	16610301	28x160	150	172	181	10	M 20	10	7,50
SZ 28-30	14615301	16615301	28x160	150	192	201	30	M 20	10	8,50
SZ 28-60	14625301	16625301	28x160	150	222	231	60	M 20	5	5,10
SZ 28-100	14630301	16630301	28x160	150	262	271	100	M 20	5	5,75

Description	Ref. No.	Drill hole Øxdepth	Setting- depth	Anchor- length	Fixture thickness t _{fix}	Thread	Pkg. cont.	Weight per pkg.
SZ-SK 10-10	14011801	10 x 65	60	70	10	M 6	50	1,97
SZ-SK 10-25	14021801	10 x 65	60	85	25	M 6	50	2,36
SZ-SK 10-40	14031801	10 x 65	60	100	40	M 6	50	2,89
SZ-SK 12-10	14111801	12 x 80	70	80	10	M 8	50	3,41
SZ-SK 12-25	14121801	12 x 80	70	95	25	M 8	50	3,98
SZ-SK 12-50	14131801	12 x 80	70	120	50	M 8	25	2,41
SZ-SK 15-10	14211801	15 x 95	85	95	10	M 10	25	3,16
SZ-SK 15-25	14221801	15 x 95	85	110	25	M 10	25	3,71
SZ-SK 15-35	14226801	15 x 95	85	120	35	M 10	25	4,08
SZ-SK 15-50	14231801	15 x 95	85	135	50	M 10	25	4,53
SZ-SK 18-20	14316801	18 x 105	95	115	20	M 12	20	4,49
SZ-SK 18-40	14326801	18 x 105	95	135	40	M 12	20	5,20

Other lengths and special assemblies on demand.



Extract from Permissible Service Conditions of ETA-02/0030

Approved loads for single anchor without influence of spacing and edge distance.
Total safety factor as per ETAG 001 included (γ_M and γ_F).

Loads and performance data	Highload Anchor SZ		SZ 10	SZ 12	SZ 15	SZ 18	SZ 24	SZ 24L	SZ 28	
			M 6	M 8	M 10	M 12	M 16	M 16	M 20	
cracked concrete										
Mean ultimate loads, tension	C25/30	N_{um}	[kN]	14,5	18,8	30,0	38,8	55,5	79,8	89,4
Mean ultimate loads, shear	C25/30	V_{um}	[kN]	22,8	31,9	46,1	84,7	116,6	116,6	171,0
Approved loads, tension	C20/25	appr. N	[kN]	2,4	5,7	7,6	12,3	17,1	21,1	24,0
	C25/30	appr. N	[kN]	2,6	6,3	8,4	13,5	18,9	23,3	26,4
	C30/37	appr. N	[kN]	2,9	7,0	9,3	15,0	20,9	25,8	29,2
	C40/50	appr. N	[kN]	3,4	8,1	10,7	17,3	24,2	29,8	33,8
	C50/60	appr. N	[kN]	3,7	8,9	11,8	19,0	26,6	32,8	37,1
non-cracked concrete										
Approved loads, tension	C20/25	appr. N	[kN]	7,6	9,5	14,3	17,2	24,0	29,6	33,5
	C25/30	appr. N	[kN]	7,6	10,5	15,7	18,9	26,4	32,6	36,9
	C30/37	appr. N	[kN]	7,6	11,6	17,4	21,0	29,3	36,1	40,9
	C40/50	appr. N	[kN]	7,6	13,4	20,1	24,2	33,8	41,7	47,3
	C50/60	appr. N	[kN]	7,6	13,8	21,9	26,6	37,2	45,9	52,0
cracked concrete / non-cracked concrete										
Approved loads, shear SZ-S and SZ-SK	C20/25	appr. V	[kN]	10,1	15,9 / 17,1	20,5 / 27,5	24,5 / 34,3	34,3 / 48,0	42,3 / 59,2	47,9 / 67,1
	\geq C25/30	appr. V	[kN]	10,1	17,1	22,6 / 27,5	27,0 / 37,8	37,7 / 52,8	46,5 / 65,1	52,7 / 73,8
Approved loads, shear SZ-B	C20/25	appr. V	[kN]	9,1	14,0	20,5 / 20,7	24,5 / 34,3	34,3 / 48,0	42,3 / 52,1	47,9 / 67,1
	\geq C25/30	appr. V	[kN]	9,1	14,0	20,7	27,0 / 36,1	37,7 / 52,1	46,5 / 52,1	52,7 / 69,7
Approved bending moments		appr. M	[Nm]	6,9	17,1	34,3	60,0	152,0	152,0	296,6

Spacing and edge distance										
Effective anchorage depth	h_{ef}	[mm]	50	60	71	80	100	115	125	
Characteristic spacing	$s_{cr,N}$	[mm]	150	180	213	240	300	345	375	
Characteristic edge distance	$c_{cr,N}$	[mm]	75	90	106,5	120	150	172,5	187,5	
Minimum spacing / for edge distance c	s_{min} / C	[mm]	50/80	60/100	70/120	80/160	100/180	100/180	125/300	
Minimum edge distance / for spacing s	c_{min} / S	[mm]	50/100	60/120	70/175	80/200	100/220	100/220	180/540	
Minimum thickness of concrete slab	h_{min}	[mm]	100	120	140	160	200	230	250	

Installation parameters										
Drill hole diameter	d_o	[mm]	10	12	15	18	24	24	28	
Diameter of clearance hole in the fixture	d_f	[mm]	12	14	17	20	26	26	31	
Depth of drill hole	h_1	[mm]	65	80	95	105	130	145	160	
Installation torque	T_{inst}	[Nm]	15/10 ¹⁾	30/25 ¹⁾	50/55 ¹⁾	80/70 ¹⁾	160	160	280	
Width across nut SZ (-S, -B)	SW	[mm]	10	13	17	19	24	24	30	
Internal hexagon size SZ-SK	SW _{Hex}	[mm]	4	5	6	8	-	-	-	
Minimum thickness of fixture for SZ-SK	$t_{fix} \geq$	[mm]	8	10	14	18	-	-	-	

¹⁾ Installation torque for type SZ-SK (with countersunk head).

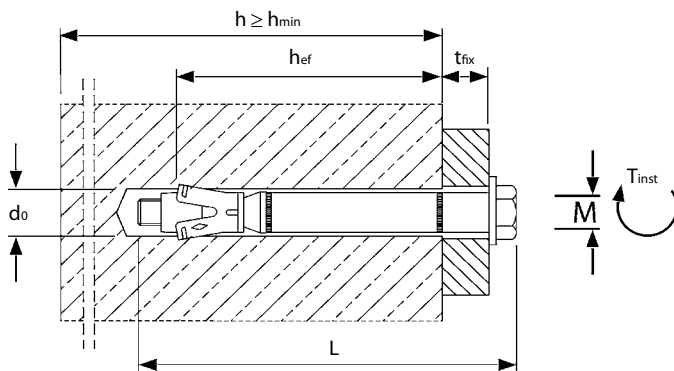

Dimensions countersunk head SZ-SK [mm]

	d1	d2	h
SZ-SK 10 M 6	16,5	9,5	3,9
SZ-SK 12 M 8	20,5	11,5	5,0
SZ-SK 15 M 10	24,5	14,5	5,7
SZ-SK 18 M 12	29,5	17,5	6,7

Countersunk head (type SZ-SK).

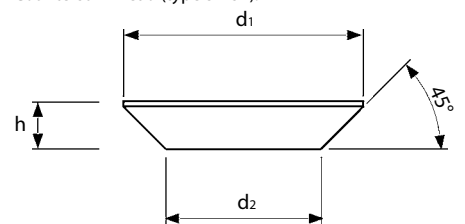

Adapter for countersunk drilling according to SL-SK (see page 39)

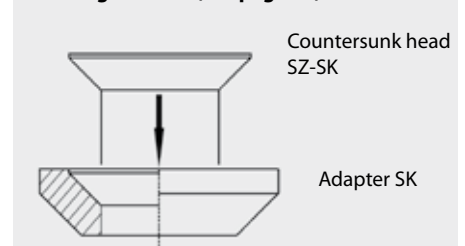

Installation

